

## Operating Manual PS-AMS 11

### Series PSL

Translation into English language

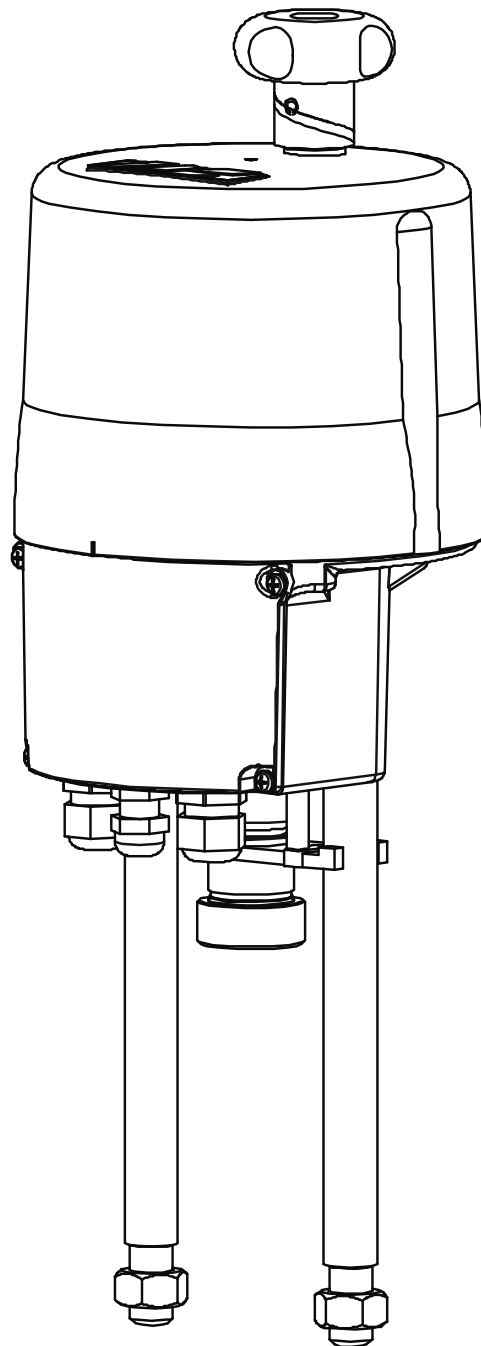

# Table of Contents

<b>1.</b>	<b>Operational Safety .....</b>	<b>4</b>
<b>2.</b>	<b>Usage as per Specification .....</b>	<b>6</b>
<b>3.</b>	<b>Installation Conditions .....</b>	<b>7</b>
<b>4.</b>	<b>Operating Principle .....</b>	<b>8</b>
<b>5.</b>	<b>Manual Operation .....</b>	<b>8</b>
<b>6.</b>	<b>Mechanical Mounting.....</b>	<b>9</b>
6.1.	Safety Notes .....	9
6.2.	Mounting to the Valve.....	10
<b>7.</b>	<b>Electrical Connection .....</b>	<b>12</b>
7.1.	Safety Note .....	12
7.2.	Wiring Diagram.....	12
7.3.	Mains Connection.....	13
7.4.	Interfaces.....	14
7.4.1.	Communication Interface.....	14
7.4.2.	Input Terminals.....	14
7.4.2.1.	Galvanically isolated Set-Value .....	14
7.4.2.2.	Sensor Feedback for Process Controller (optional) .....	14
7.4.2.3.	Galvanically isolated Binary Inputs.....	15
7.4.2.4.	Fail-Safe Port for Binary Input.....	15
7.4.3.	Output Terminals .....	15
7.4.3.1.	Active Position Feedback .....	15
7.4.3.2.	Additional Position Switches (optional) .....	15
7.4.3.3.	Voltage Feed to Process Sensor (optional).....	16
7.4.3.4.	Fault Indicating Relay (optional).....	16
7.4.3.6.	Fieldbus Interface (optional).....	16
7.5	Accessories .....	17
7.5.1	Space Heater (optional).....	17
7.5.2	Adjusting Additional Position Switches (optional).....	18

<b>8.</b>	<b>Status Display / Operating Element.....</b>	<b>19</b>
8.1.	LEDs inside Terminal Box .....	19
8.2.	Commissioning Button.....	19
<b>9.</b>	<b>Operation.....</b>	<b>20</b>
9.1.	Cut-off in End Positions .....	20
9.1.1.	Cut-off by Force / Torque .....	20
9.1.2.	Cut-off Position automatically .....	20
9.1.3.	Cut-off by Position .....	20
<b>10.</b>	<b>Commissioning .....</b>	<b>21</b>
10.1.	Automatic Commissioning .....	21
10.2.	Manual Commissioning .....	23
<b>11.</b>	<b>Status Messages.....</b>	<b>24</b>
11.1.	Fault Indicator Relay.....	24
11.2.	Tracing Faults .....	24
<b>12.</b>	<b>Maintenance and Repair .....</b>	<b>24</b>
<b>13.</b>	<b>Safety on Transportation .....</b>	<b>24</b>
<b>14.</b>	<b>CE-Declaration .....</b>	<b>26</b>
<b>15.</b>	<b>Agencies/ Representatives.....</b>	<b>27</b>
	<b>Appendix: Itemisation.....</b>	<b>28</b>

## 1. Operational Safety

**General Information** This operating manual is an integral part of the actuators PSL-AMS11 and must be kept available to operators at any time.

All safety notes and information contained in this manual must be followed.

Please note that in case of unintended use and/or inappropriate operation the manufacturer is released from all liabilities.

The chapter on Operational Safety contains some fundamental safety instructions to be strictly observed when working with the actuators PSL-AMS11.

In addition to this, further safety instructions concerning individual action steps can be found in various sections of this manual. These are highlighted by special warning signs.

### Issue Issue 2

21.06.2007

Upon receipt of this operating manual, all manuals bearing an earlier date of issue and having been supplied prior to this issue become void.

### Safety Notes



Danger!

...warns of hazards due to electric current within buildings or when using machines or tools.



Caution!

...warns of dangerous spots. Contains information, instructions and interdictions to avoid injuries or damage.

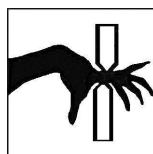

Danger!

... warns of hazards posing a risk to health. Ignoring these instructions can lead to injuries.

**Dangers resulting from non-observance of safety notes**

The actuators PSL-AMS11 are designed according to the state of the art and in compliance with European standards and are safe to operate. The actuators may however cause dangers if not operated by trained and instructed personnel. Safety of operation can only be guaranteed for intended and appropriate use.

Non-observance of these guidelines can:

- result in dangers to health and life of operators or third persons
- damage the actuator and other assets of the user
- pose risks to the actuator's efficient functioning.

In the interest of your personal safety, please pay attention to these instructions before installation, commissioning, operation, maintenance and repair. Any person in charge of the tasks mentioned above must have read and fully understood the contents of this manual, especially the sections relevant to safety.

**Safe Operation**

The actuators may only be operated by trained and authorized personnel.

Prior to repair work on the actuator, voltage must be disconnected. Repair work on the unit shall only be executed when the actuator is at rest.

To ensure a safe operation, it is necessary to check whether the unit is free from visible damage or defects. Disturbances of its operating performance must be localised and eliminated immediately.



**Beware of mechanical hazards due to electrically powered actuator components!**

**With the actuator powered electrically, operating the unit holds the danger of crushing your fingers.**

During the installation of the actuator and the valve, the unit must not be powered electrically.

Previous to maintenance and adjustment work, voltage must be disconnected from the actuator. The unit must also be safeguarded against unintentional restarting.

**Upgrade and accessory parts**

Upgrading and operating the actuator with PS accessory parts requires observance of the respective operating manuals.

## 2. Usage as per Specification

The linear actuators PSL-AMS11 are exclusively designed for the use as electric valve actuators. They are destined for the assembly with valves and for their motor actuation. The actuators must not be operated outside the limits specified in data sheets and catalogues.

Any other usage is assumed to be prohibited. The manufacturer is not liable for any damage resulting thereof. Furthermore, unpredictable situations of danger may result from prohibited usage.

Usage as per specification also comprises observance of operating, maintenance and repair processes as stipulated by the manufacturer.

To avoid dangers in normal operation:

- Only employ trained personnel for all types of work.
- Observe accident prevention regulations.
- Observe any internal working, operating and safety instructions that may exist.

### **Note**

PS Automation is not liable for damages resulting from arbitrary changes to the actuators.

### 3. Installation Conditions

**Storage** Storage requirements to be observed:

- Only store the actuators in well ventilated and dry spaces.
- Only store them on shelves, wooden grids etc. to ensure protection against rising moisture.
- Protect from dust and dirt using a plastic foil.
- Protect the actuators against mechanical damage.

**Operating conditions** Ambient temperature -20°C to +60°C  
Mode of operation IEC 34-1, 8: S2 for step operation, and S4 for modulating operation  
(actuator specific values to be sourced from relevant data sheet)  
Degree of protection IP 65 (optionally IP 67) according to EN 60529

**Mounting position** Any mounting position allowed except „cap pointing down“.

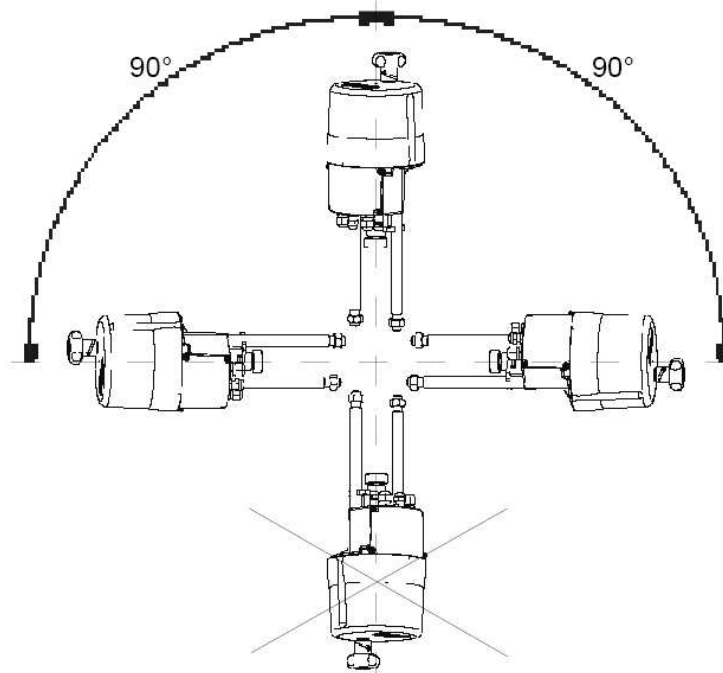

**Installation dimensions** The actuators must be built in with a sufficient clearance to facilitate the removal of the cap. (see figure below).

## 4. Operating principle

**Operating principle** The linear actuators PSL-AMS are designed for the use as electric valve actuators. Mounting to the valve is done via the actuator pillars. Depending on the valve design, a lantern or a special mounting plate will be required.

The motor torque is transmitted via a multi-step spur gear to a trapezoidal thread spindle. The spindle itself converts the induced torque into an axial force via a spindle nut. The spindle nut's resulting linear vertical motion is self-locking and is transmitted via a coupling piece to the valve stem.

During power failure and adjustment work the actuators can be emergency-operated via the hand wheel (see chapter 5/Manual Operation), except when using the fail-safe unit PSEP.

## 5. Manual Operation

**Manual operation** A hand wheel is provided to operate the actuator in case of power failure or for valve adjustment. If a fail-safe unit type PSEP (option) is installed, this has to be disconnected to enable the actuator to be operated by hand wheel. .

At actuators of the series PSL201-204, PSL208-210 and PSL305-314 the hand wheel is tuning during motor operation. The actuators PSL320-325 are equipped with a declutchable hand wheel, that is standing still during motor operation. To operate these actuators manually, the knob at the top of the cover must be depressed and held down.



### Caution!

The hand wheel should not be used in ongoing operation, as, the actuator tries to compensate the deviation in position, depending on the operating mode.

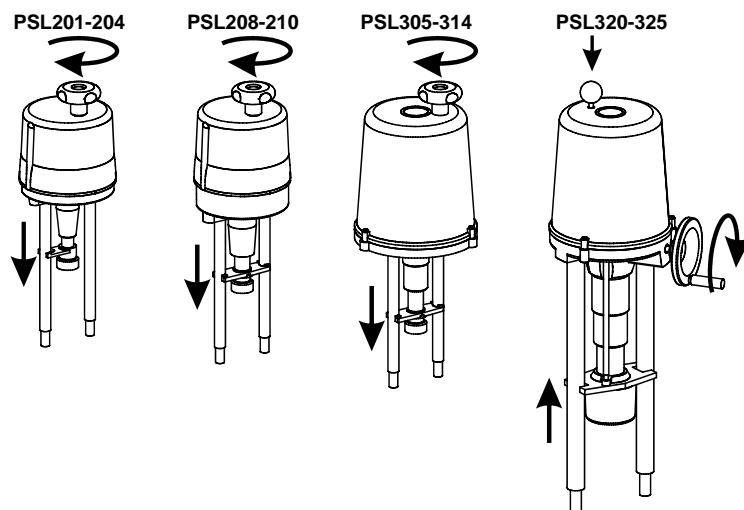

Manual operation





If a fail-safe device PSEP (option) is fitted to the actuator, this has to be disconnected electrically to allow to drive the actuator by hand wheel. Open the cover of the PSEP and disconnect the cable from the minus terminal, see picture below. There is safety-low voltage (24V) present.

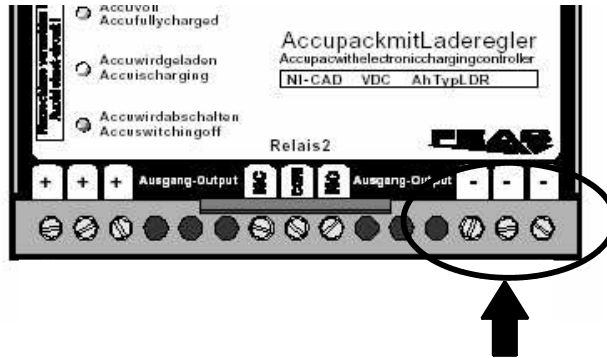

## 6. Mechanical Mounting

### 6.1. Safety note

**Safety note** Beware of mechanical hazards due to electrically powered actuator components!

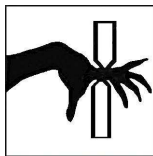

With the actuator powered electrically, operating the unit holds the danger of crushing your fingers, damaging the actuator and/or the valve.

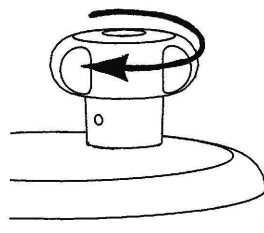

*Note: All mentioned items refer to the itemisation as shown on the page after page 24.*

During adjustment work, the actuator may be operated by means of the hand wheel only. Do not operate electrically!

## 6.2. Mounting to the valve

### How to mount the actuator

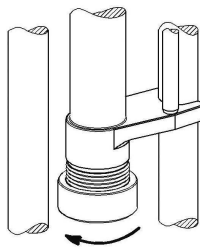

Unscrew the locking nut (item 10) from the spindle nut (item 9).

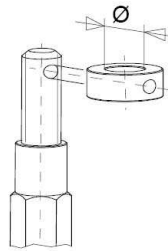

Check whether the coupling piece (item 15) is drilled as per the valve stem's end (item 11). If necessary, re-machine.

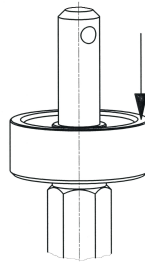

Place the locking nut (item 10) over the valve stem (item 11).

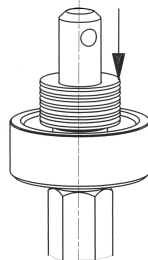

Place the disc springs (item 16) over the valve stem.

Observe the various arrangements for the disc springs! (see next figure).

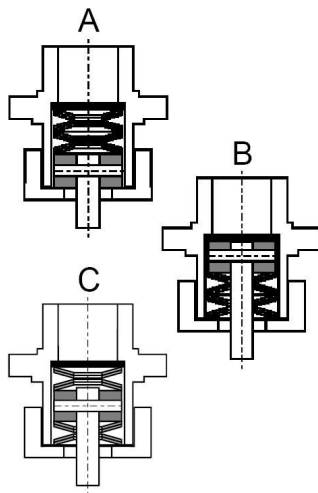

The arrangement of the disc springs varies according to the type of valve. There are three versions:

A: Arrangement for two-way valves with closing direction „valve stem retracting“

B: Arrangement for two-way valves with closing direction „valve stem extending“

C: Arrangement for three-way Valves

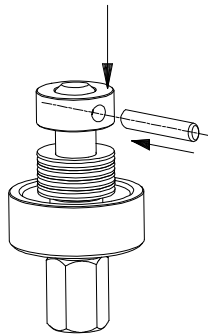

Screw the coupling piece (item 15) onto the valve stem, drill the semi-drilled hole completely through and secure with the pin (item 14).

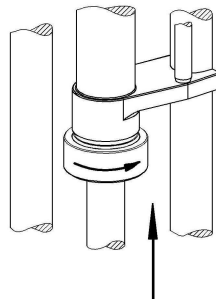

Insert the assembly of valve stem, coupling piece and disc springs into the spindle nut. Re-adjust its position accordingly with the hand wheel. Screw the locking nut on and tighten it with the wrench supplied with the actuator.

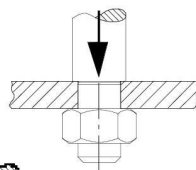

Introduce the pillars (item 12) into the bore holes at the valve bonnet and tighten them with the nut (item 13).

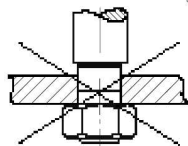

Before tightening the nut, both pillars must be fed completely into the bore holes at the valve bonnet. If necessary, the spindle nut's position has to be adjusted with the hand wheel. Non-observance may cause damage to the actuator!

## 7. Electrical Connection

### 7.1. Safety Note

**Safety note** When performing electric work on this unit, the local accident prevention regulations must be followed.



Observe EN 60204-1 (VDE 0113 part 1) to ensure human safety, integrity of the assets as well as the proper functioning of the unit.

Electric supply lines must be dimensioned for the peak current of the unit and comply with IEC 227 and IEC 245. See relevant data sheet.

Yellow-and-green coded cords may only be used for connection to protective earth.

When leading wires through the cable glands on the actuator, their minimum bending radius has to be considered.

The electric actuators PSL-AMS are not fitted with an internal electric isolator, hence a switching device or circuit breaker must be integrated in the facility. It should be installed close to the actuator and should be easy to access for the user. It is important to mark the circuit breaker as this actuator's isolator.



Electric installations and over-current protection devices must conform to the standard IEC 364-4-41, protective class I.

### 7.2. Wiring Diagram

**Wiring Diagram** Electric terminals are provided in a terminal box at the actuator.

1	2	3	4	5	6	7	8	9	10	11	12	13	14	15	16	17	18	19	20	21	22	23	⊕		RJ-45 TTL	Taster Button	
↑	↑	↑	↓	↓	↓	↕	↕	↑	↑	↑	↑	↑	↓	↑	↑	↑	↕	↕	↕	↕	↑	↑	⊕				
+ 0(2) - 10 V	+ 0(4) - 20 mA	GND	+ 0(2) - 10 V	+ 0(4) - 20 mA	GND	max. Last / max. Load 100 mA bei / at 24 VDC		L+/ AUF/ OPEN	N/-	L+ ZU/ CLOSE	L+ (24V AC/DC)	N- (24V AC/DC)	24 VDC / 100 mA	+ 0(2) - 10 V	+ 0(4) - 20 mA	GND	(Option)	(Option)	(Option)	(Option)	L+ (siehe Typenschild/ see tag plate)	N- (siehe Typenschild/ see tag plate)	PE	(Option)			
Sollwert-Eingang	Aktive Positions-rückmeldung	Störmeldung potentialfrei	Binäre Ansteuerung	Netz-ausfall-signal	Ver-sor-gung	Istwert	Zu / Closed	Auf / Open	Wegschalter potentialfreier Kontakt	Versorgungs-spannung	Feldbus-Anschluß	PC Kommu-nikation	Inbetrieb-nahme														
Set value input	Active position feedback	Monitor relay potential-free	Binary input signals	Fail safe signal	Supply	Actual value	Position switch potential-free contact	Power supply voltage	Fieldbus interface	PC communication	Commissioning																
Galvanisch getrennt / Galvanically isolated 1 kV													Process-Sensor														

Wiring diagram

8013770 - S-217\_E

### 7.3. Mains supply

#### Mains supply

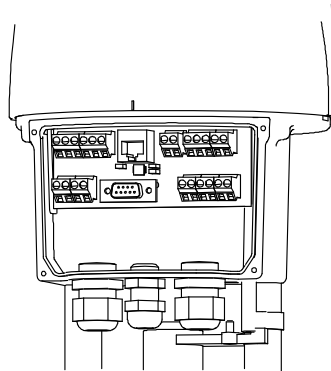
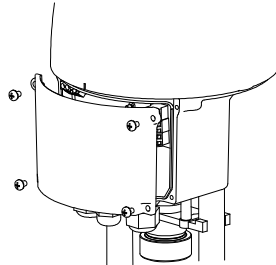

Isolate the power supply.  
Safeguard the line against  
unauthorized and unintended  
restarting.

Open the terminal box.

The terminal box provides  
terminals to accommodate rigid  
and flexible cables of wire widths  
of 0.14 mm<sup>2</sup> to 2.5 mm<sup>2</sup> as well  
as a PE screw on the housing.

**Caution:** Please observe the  
supply voltage and the maximum  
power consumption of the  
actuator as indicated on the  
actuator's tag plate!

Connect supply and control lines  
to terminals (as indicated in the  
wiring diagram).

## 7.4. Interfaces

**Interfaces** The actuator AMS11 has several interfaces inside the terminal box which can be configured by the parameterising software PSCS or by the control box PSC (see relevant manuals).



### 7.4.1. Communication Interface

For communication and parameterisation with a PC or a hand-held device, connect the communication cable to the RJ45-connector (item 4). Actuator parameters can be set using the software PSCS or the control box PSC (see relevant manuals).

### 7.4.2. Input Terminals

#### 7.4.2.1. Galvanically isolated Set-Value

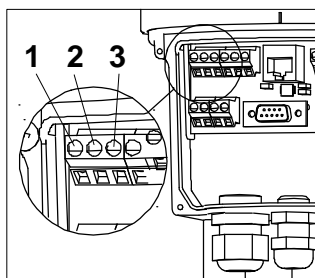

Terminals 1 through 3 are used to receive a parameterisable modulating set-value for control operation within the range of 0-20 mA or 0-10V.

#### 7.4.2.2. Sensor Feedback for Process Controller (optional)

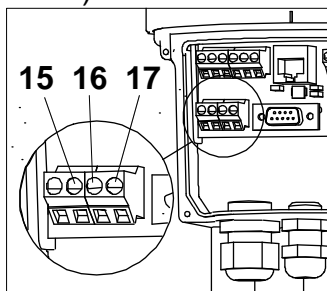

Terminals 15 through 17 are used to receive a process sensor's feedback to the - optional - process controller, in the parameterisable range of 0-20 mA oder 0-10 V.



#### **Caution!**

The following binary inputs (7.4.2.3 & 7.4.2.4) have priority over the modulating set-value. If the actuator is parameterised for modulating service, these set-value settings are disregarded in the case a binary signal is applied. Only after disconnection of the binary signal the actuator will reposition according to the set-value applied.

### 7.4.2.3. Galvanically Isolated Binary Input

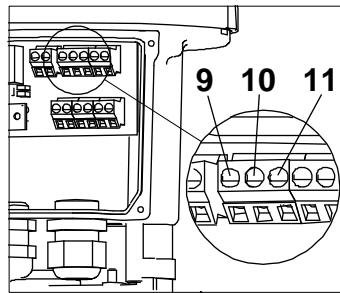

Terminals 9 through 11 are for binary open/close signals. Standard voltage level is 24 V, option is for 115/230 V; see wiring plan. The actuator is then driven in 3-point service.

### 7.4.2.4. Fail-safe port for Binary Input (optional)

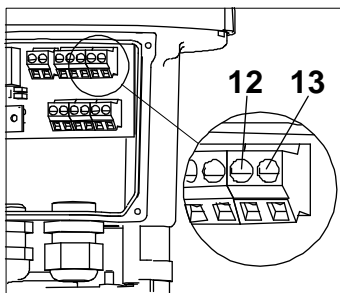

The fail-safe port (terminals 12 and 13) allows to drive the actuator to a parameterised safety position by applying a voltage of 24 V.

## 7.4.3. Output Terminals

### 7.4.3.1. Active Position Feedback

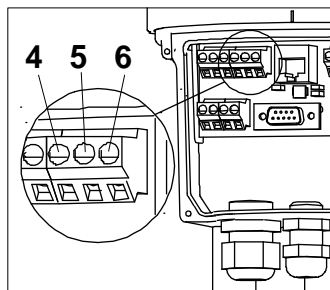

Terminals 4 through 6 are giving active position feedback, parameterisable within the range of 0-20mA or 0-10V. See also "9.1 Cut-off in end positions"!

### 7.4.3.2. Additional Position Switches (optional)

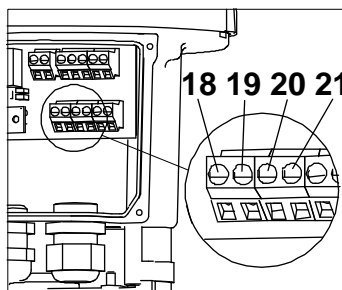

The activation points of the optionally available position switches are freely adjustable via cams. Terminals 18/19 and 20/21 provide potential-free opening or closing contacts. The standard switches are rated to 230VAC/5A. Special switches with gold plated contacts are available for low power (up to 100 mA and 30V).

#### 7.4.3.3. Voltage feed to Process Sensor (optional)

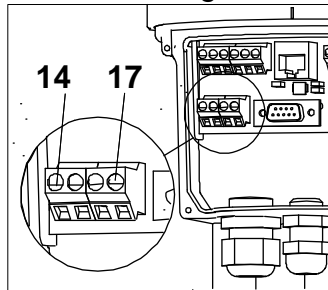

Terminals 14 and 17 provide an unregulated output voltage of 24 to 30 VAC at maximum 100 mA to feed an external process sensor.

#### 7.4.3.4. Fault Indicating Relay (optional)

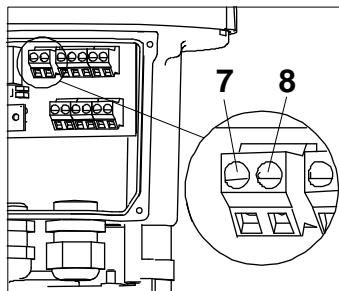

This potential-free normally-open relay contact (terminals 7 and 8) allows to display parameterisable fault indication to the control room. See instruction manual for software PSCS.

#### 7.4.3.5. Fieldbus Interface (optional)

Optionally a fieldbus interface can be fitted to the AMS-actuator, with wiring to a terminal block or an external socket.  
-> See special operating manual for AMS-Fieldbus.



## 7.5. Accessories

### Space Heater 7.5.1. Space Heater (optional)

Actuators PSL-AMS can be fitted with a space heater. When using actuators in environments with high temperature fluctuations or high humidity, we suggest a heating resistor be fitted to prevent the build-up of condensation within the enclosure.

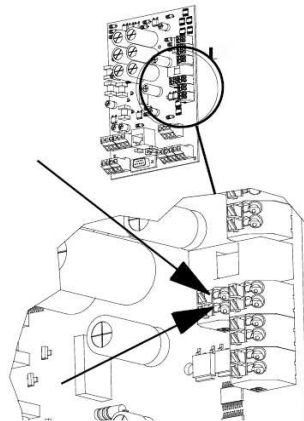

In actuators PS-AMS the space heater is powered via the power supply of the actuator, so it does not have to be fed separately. For retro-fitting the heating resistor, wiring of the two cables has to be made to the terminals on the main board as per the picture on the left.

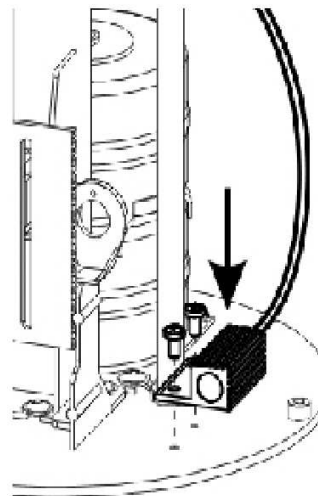

Mounting of the space heater has to be made to the indicated place on the base plate by using the screws provided. Route the cables in a way to prevent them from being squashed by the main cover, and from being touched by moving parts inside the actuator.

### 7.5.2. Adjusting Additional Position Switches (optional)

#### **Position Switches**

In PSL-AMS two switches for position feedback are available as factory-mounted option. They are either normally-closed or normally-open contacts, potential free. They are available with silver contacts (for currents between 10 mA and 5 A at maximum 230 V) or with gold-plated contacts (for currents between 0,1 mA and 30 mA at maximum 30 V). Connection goes to terminals 18/19 and 20/21.

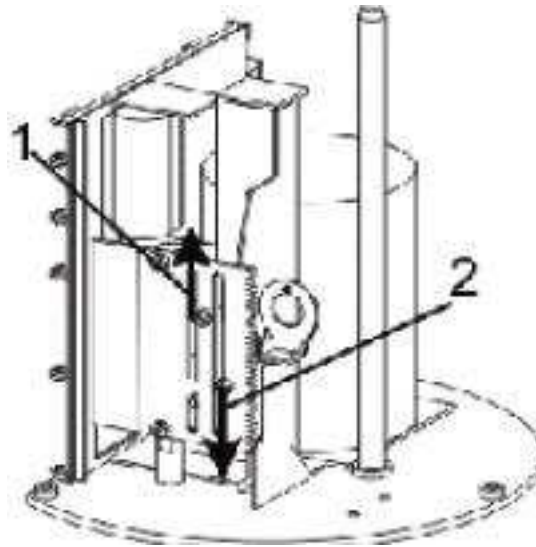

The cams for closing the switches are located on the switch plate, and are adjustable with a small screwdriver. Cam 1 is for retracting the spindle nut, while cam 2 is for extending the spindle nut out of the actuator.

## 8. Status display / Operating element

### 8.1. LEDs inside terminal box

#### LEDs inside terminal box

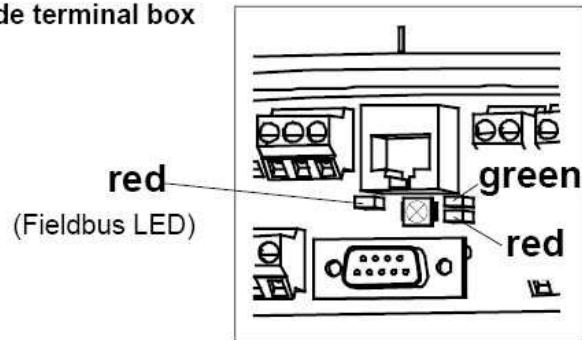

A red and a green LED on top of each other (item 7) inside the terminal box indicate the status of the actuator.

A further single red LED (optional) signals the status of the optional fieldbus interface. -> See special operating manual for AMS-Fieldbus.

### 8.2. Commissioning button

#### Commissioning button

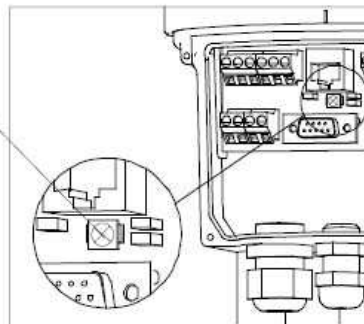

The commissioning button (item 6) for starting the automatic commissioning run (to adjust the actuator to the valve) is located inside the terminal box, below the communication port. -> See chapter 9.1 "Cut-off in end positions"

## 9. Operation

All internal parameters, like required motor torque, actual position, functional status, etc., are being permanently monitored during operation of the actuator PS-AMS. This ensures that the actuator positions with optimum accuracy, and closes the valve always tight. Deviations can be read out via communication software PSCS or via local control PSC.2 (see respective instruction manuals), or can be displayed to the control room using the optional fault indication relay. This provides maximum safety of the process.

### 9.1. Cut-off in End Positions

**Cut-off in End Positions** Cut-offs of the PS-AMS actuators can be adjusted to meet the valve function in an optimum way by using the communication software PSCS (using a special interface cable, or optionally Bluetooth connection). This will result in different behaviour of the actuator. In case a position is surpassed or not reached, this can be read out via the optional Fault Indication Relay or via the communication software PSCS.

#### 9.1.1. Cut-Off by Force / Torque

The actuator delivers the programmed maximum force / torque each time when driving to this end position. If the closing point inside the valve dislocates, e.g. when a seat gasket wears, then the actuator will drive further in its possible actuation range to try to reach the programmed force / torque.

#### 9.1.2. Cut-Off by Position automatically

In normal operation, the actuator will stop at the position which was found at a mechanical stop in the valve or the actuator during Automatic Commissioning. If the closing point inside the valve dislocates, the actuator will NOT follow this dislocation but it will always stop at the point initially found.

#### 9.1.3. Cut-Off by Position

In normal operation, the actuator will stop at the point which was defined by Manual Commissioning. This position is not depending on any mechanical stop inside valve or actuator.

## 10. Commissioning

The actuator is shipped in the „not commissioned“ condition with the green LED (item 7) flashing slowly. There will be **no** response to any input (set value or open/close signal). To make the actuator operational, it has to be commissioned to a valve.

Depending on the type of cut-offs programmed (see 9.), there are two ways to do commissioning:

- **Automatic** commissioning is done if at least one of the cut-offs is set to be “by force/torque” or “by position automatically”.
- **Manual** commissioning has to be made in case both cut-offs are “by position”, either via software PSCS or via control box PSC.2.



### **Caution!**

Electrical operation of the actuator is allowed only after mounting to a valve!

### 10.1. Automatic commissioning

**Automatic commissioning** This is performed if at least one of the cut-offs is set to be “by force/torque” or “by position automatically”.

During automatic commissioning the actuator goes through the full programmed valve stroke / angle automatically. Parameters specific to the valve are being measured and calculated values are permanently stored in the actuator. At the same, set value and position feedback range are scaled.

To enable Automatic Commissioning, a mechanical stop is required in at least one end position (usually the closed position) of the valve. This mechanical stop can be either given by design of the valve, or it may be adjusted by the stop screws of the actuator (only when cut-off “by position automatically” is programmed).

**Procedure:**



- a.) Mount the actuator to a valve, wire it and switch the power on, according to these instructions. Press the button (item 6) inside the terminal box for at least 3 seconds.

Commissioning in progress !



- b.) The automatic commissioning run starts and the actuator moves through the whole valve stroke. The green LED flashes quickly during this commissioning run.

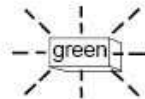
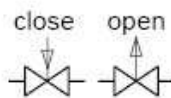

- c.) After finishing the automatic commissioning, the actuator is ready for use. The green LED is glowing permanently.

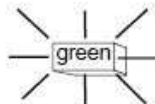

**Note**

If the actuator is stalled during the automatic commissioning run BEFORE reaching a desired position-dependent cut-off, it will then store the so-obtained stroke.

**Note**

If, as a result of automatic commissioning, no force/torque limit is found, or if a stroke below the minimum allowed stroke (5 mm in standard version) is found, the commissioning run will be aborted. The actuator returns to the “not commissioned” condition (i.e. green LED flashing slowly), even if the actuator had been initialized correctly before that.

**Note**

Automatic commissioning can be started via software PSCS or via control box PSC as well. -> See relevant operation manuals



**Caution!**

If the LEDs display other types of signals than “flashing green” or “glowing green permanently”, please refer to the chapter on “Fault messages”.



**Caution!**

The mains supply must not be interrupted during the commissioning run!

## 10.2. Manual commissioning

**Manual commissioning** If both cut-offs are selected to be „by position“, the actuator must be commissioned manually using the software PSCS or the control box PSC.



oder

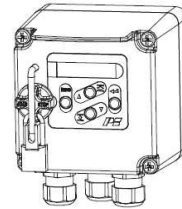

### Procedure:

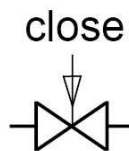

- a.) Mount the actuator to a valve, wire it and switch the power on, according to these instructions. Permanently apply the set-value for the closed position, or the input signal „close“.



### Caution!

The valve stroke has to be parameterised using software PSCS or control box PSC! -> See relevant manuals.



oder

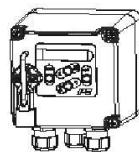

zu



- b.) Drive the actuator to the closed position of the valve using software PSCS or control box PSC. The open position of the valve will be calculated in accordance with the programmed valve stroke.

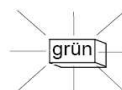

- c.) After manual commissioning, the actuator is ready for use. The green LED is glowing permanently.

### Note

If the parameterised valve stroke, starting from the adjusted closed position, exceeds the possible actuator stroke, then the operating stroke will be reduced to the resulting maximum possible value.

## **11. Status messages**

### 11.1. Fault indicator relay

**Fault indicator relay** Fault messages can be transmitted to control boards with a maximum load of 24 VDC/100 mA via an optionally available closing contact at terminals 7 and 8. The messages can be parameterised via software PSCS or control box PSC. -> See relevant manuals

### 11.2. Tracing faults

See the table on page 25 for explanation of the blinking codes of the status-LEDs.

## **12. Maintenance and repair**

Under the conditions of use as per specification as lined out in the data sheet, the PS-AMS actuators are free of maintenance. All gears are lubricated for their service life and do not require to be re-lubricated.

**Cleaning** Clean the actuators with a dry soft cloth and do not use any cleaning agent. Do not use any coarse or abrasive materials.

## **13. Safety on Transportation**

For transportation and storage all cable glands and connection flanges have to be closed to prevent ingress of moisture and dirt. A suitable method of packaging is required for transporting to avoid damage of coating and any external parts of the actuator.

## **14. CE - Declaration of Conformity**

See page 26



## 11.2. Tracing Faults

Red LED			Green LED							
glowing permanently	flashing quickly	flashing slowly	off	glowing permanently	flashing quickly	flashing slowly	off			
								<b>Status</b>	<b>Probable reasons</b>	<b>Possible remedy</b>
			x				x	Actuator does not respond, both LEDs are off	1) No supply voltage applied 2) The applied voltage does not match the actuator voltage on the tag plate	1) Check mains supply 2) Apply correct supply voltage
			x	x				Actuator does not drive the full valve stroke	1) Actuator not correctly commissioned 2) Too small stroke programmed (in mode "one position-dependent cut-off")	1) Repeat commissioning 2) Check valve stroke parameters -> see instruction AMS-PSCS
			x	x				Actuator does not close the valve properly	1) Actuator not correctly commissioned 2) Actuator closing force/torque too low	1) Repeat commissioning 2) Check actuator selection
			x	x				Actuator is in normal operating condition, but does not respond to set-value changes	1) Fixed digital set-value is activated 2) Actuator is configured to work with process controller	1) Check set-value parameters, -> see instruction AMS-PSCS 2) Connect process sensor
			x	x				Actuator position does not correspond to set-value input	A non-linear valve curve has been parameterised.	Verify parameterised characteristic -> see instruction AMS-PSCS
								<b>Operating conditions</b>	<b>Probable reasons</b>	<b>Possible remedy</b>
			x	x				Normal operating condition		
			x		x			Actuator in commissioning mode		Commissioning mode will be left automatically after completion
			x			x		Actuator not commissioned		Depending on the type of cut-offs, the actuator has to be commissioned either automatically or manually.
								<b>Faults within the actuator's environment</b>	<b>Probable reasons</b>	<b>Possible remedy</b>
		x		x				Too high torque has been encountered within the valve stroke	1) Actuator not correctly commissioned to the valve 2) Mechanical block within the stroke path 3) Improper selection of the actuator	1) Repeat commissioning 2) Check valve and actuator for unobstructed running 2) Check actuator selection
		x			x			1) No proper process feedback (only in combination with PSIC) 2+3) Maximum control range exceeded (only in combination with PSIC)	1) Process feedback wrongly or not at all connected 2) Process feedback outside od adjusted range 3) No process sensor signal available	1) Apply the correct process feedback signal and check polarity 2) Ensure the correct process feedback range 3) Check the process sensor and its supply voltage
		x				x		Actuator is driving into a preset position	1) Signal is applied to the binary fail-safe input 2) Supply voltage failure on actuators with optional PSEP	1) Disconnect the signal 2) Check supply voltage
		x					x	Set-value disconnected or outside the parameterised range	1) Set-value not connected 2) Wrong polarity of set-value 3) set-value signal outside parameter range, please check	1) Apply set-value 2) Check the set-value polarity 3) Check the set-value range
	x			x				Stored end position could not be reached	Loose or dirty valve seat	Check the valve seat
	x				x			Stored end position ment has been passed over	Valve seat worn or defective	Check the valve seat
		x					x	Actuator supply voltage too low	1) Improper wiring of the mains supply 2) Jitter in supply voltage 3) Too low supply voltage from PSEP (with optional PSEP)	1) Check mains wiring 2) Check supply voltage -> see datasheet 3) Contact PS service team
								<b>Faults within the actuator</b>	<b>Probable reasons</b>	<b>Possible remedy</b>
x				x				Actuator has reached lifetime limit	Wear and/or running time	Contact PS service team
x					x			Faulty electronics or invalid parameters	1) Supply voltage interrupted during commissioning 2) Defective electronic component	1) Re-load parameters (-> see manual AMS-PSCS), then repeat commissioning 2) Contact PS service team
x						x		Critical or maximum temperature reached	1) Too high number of starts 2) Ambient temperature too high	1) Check application and its adjustment 2) Check ambient temperature and try to reduce it -> see relevant data sheet
x							x	Mechanical fault in the actuator	Defective mechanical part	Contact PS service team

## Declaration of Conformity

We,  
**PS Automation GmbH**  
**Philipp-Krämer-Ring 13**  
**D-67098 Bad Dürkheim**  
**Germany**

declare under our sole responsibility that we are manufacturing the electrical actuators of series

**PSL...; PSQ...; PSR...; PSL-AMS...; PSQ-AMS...**

according to the following EEC regulations:

<b>89/336/EEC</b>	Electro-magnetical Compatibility
<b>73/23/EEC</b>	Low Voltage Directive

and that we have successfully tested them as per the following harmonized standards:

EN 61000-6-2: 2001	Electro-magnetical compatibility (EMC), Generic standards Immunity for industrial environments
EN 61000-6-4: 2001	Electro-magnetical compatibility (EMC), Generic standards Emission standard for industrial environments
EN 61010-1: 1995	Safety Requirements for Electrical Equipment for Measurement, Control and Laboratory use

Bad Dürkheim,  2004



Max Schmidhuber  
(General Manager)

### CAUTION!

To ensure compliance of these actuators with the above directives, it is the responsibility of the specifier, purchaser, installer and user to observe the relevant specifications and limitations when taking the product into service. Details are available on request, and are mentioned in the Installation and Maintenance Instructions.

## 15. Vertretungen / Representatives

### Italy

G.E.I. s.r.l.  
Via Pennella, 94  
I-38057 Pergine Valsugana  
(TN)  
Tel.: <+39> 04 61-53 25 52  
Fax: <+39> 04 61-53 31 17  
eMail: GEI@dnet.it

### Spain

SERTEMO, S.L.  
Pol. Ind. Alba - Avda.  
Generalitat 15  
Apartado de Correos, 142  
E-43480 Vila-Seca (Tarragona)  
Tel.: <+34> 977-39 11 09  
Fax: <+34> 977-39 44 80  
eMail: sertemo@sertemo.com  
www.sertemo.com

### Denmark

Gustaf Fagerberg A/S  
Kornmarksvej 8-10  
DK-2605 Brøndby  
Tel.: <+45> (0) 43 29 02 00  
Fax: <+45> (0) 43 29 02 02  
eMail: jo@fagerberg.dk  
www.fagerberg.dk

### Netherlands, Belgium

AMAL Automation B.V.  
De Dijken 5.A  
NL-1747 EE Tuitjenhorn  
Tel.: <+31> (0) 22-4 55 23 16  
Fax: <+31> (0) 22-4 55 23 17  
eMail: info@omal.nl

### China

SHENZHEN MAXONIC  
AUTOMATION  
Control Co Ltd.  
7<sup>th</sup> Floor, Block 7, Tian An  
Industrial Estate  
Nanyou, Shenzhen, Guangdong  
P. R. CHINA  
Tel.: <+86> 7 55 26 52 18 78  
Fax: <+86> 7 55 26 05 28 00  
eMail:  
szmaxoni@public.szptt.net.cn

### Hong Kong

PS-MAXONIC Hong Kong Ltd.  
Room 803-4, Yale Industrial  
Centre  
61-63 Au Pui Wan Street  
Fotan, Shatin, Hong Kong  
Tel.: <+852> 26 87-50 00  
Fax: <+852> 81 01-37 43  
eMail: simon@maxonicauto.com  
www.maxonicauto.com

### Singapore

BEAVER CONTROMATIC  
30 Shaw Road #02-02 to 06  
SGP-Singapore 367957  
Tel.: <+65> 67 46 96 77  
Fax: <+65> 67 43 11 94  
eMail: bcvalves@pacific.net.sg  
www.beavercontro.com

### Great Britain

IMTEX Controls Ltd.  
Unit 5A, Valley Industries,  
Hadlow Road  
GB-Tonbridge, Kent TN11 0AH  
Tel.: <+44> (0) 17 32-85 03 60  
Fax: <+44> (0) 17 32-85 21 33  
eMail: sales@imtex-controls.com  
www.imtex-controls.com

---

### PS Automation GmbH

Gesellschaft für Antriebstechnik  
Philipp-Krämer-Ring 13

### D-67098 Bad Dürkheim

Tel.: <+49> (0) 63 22-60 03-0  
Fax: <+49> (0) 63 22-60 03-20

e-mail: Info@ps-automation.com  
Internet: http://www.ps-automation.com

- 1 Hand wheel
- 2 Terminal box
- 3 Terminals
- 4 Communication port
- 5 Fieldbus socket (option)
- 6 Commissioning button
- 7 LEDs
- 8 Stroke scale
- 9 Spindel nut with anti-rotation lock
- 10 Locking nut
- 11 Valve stem
- 12 Actuator pillar
- 13 Nut
- 14 Locking pin
- 15 Coupling piece
- 16 Disc springs

